

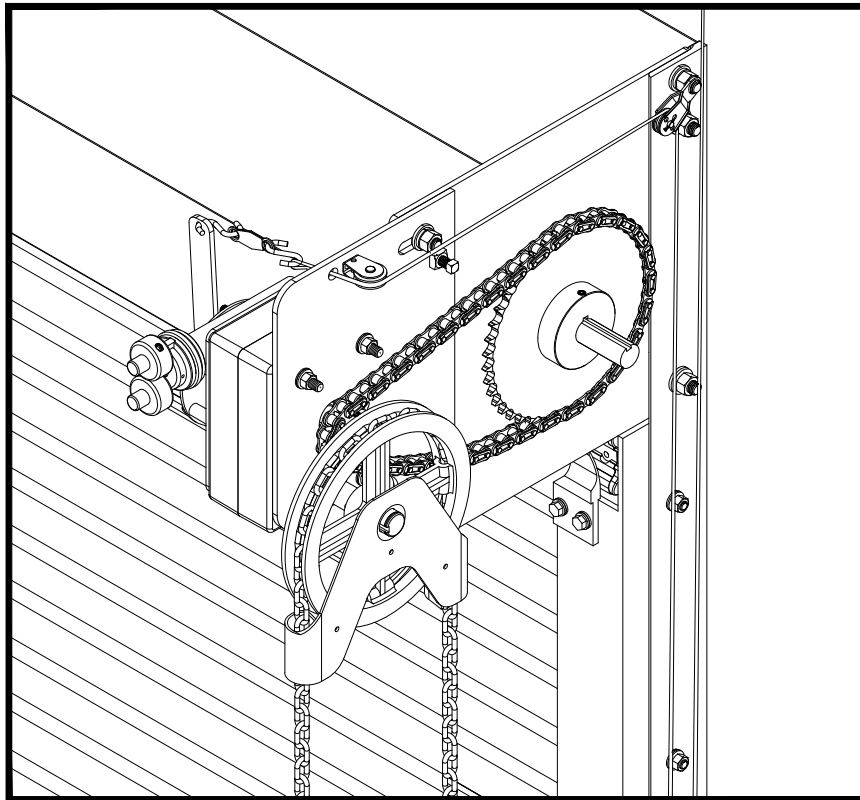

# ASTA AMERICA

BY JANUS INTERNATIONAL

## FIRE DOOR 500 SERIES CHAIN HOIST GOVERNOR INSTALLATION MANUAL



**READ ENTIRE MANUAL BEFORE  
BEGINNING INSTALLATION**

Important note: This installation manual must be used in conjunction with the ASTA America Base Fire Door Installation Manual that is packaged with this fire door. The information in these two manuals is suitable for future maintenance inspections, drop testing and resetting procedures. These manuals should be made the property of the owner upon completion of the installation.

**ASTA AMERICA**

CARTERSVILLE, GA  
ASTAAmerica.com

# SAFETY INFORMATION

## OVERVIEW OF POTENTIAL HAZARDS

Overhead doors are large, heavy objects that move with the help of springs under high tension and electric motors. Since moving objects, springs under tension, and electric motors can cause injuries, your safety and the safety of others depend on you reading the information in this manual. If you have questions or do not understand the information presented, call your nearest service representative.

In this section, and those that follow, the words "Danger", "Warning", and "Caution" are used to emphasize important safety information. For example:

 **DANGER:** Indicates an imminently hazardous situation which, if not avoided, will result in death or serious injury.

 **WARNING:** Indicates a potentially hazardous situation which, if not avoided, could result in death or serious injury.







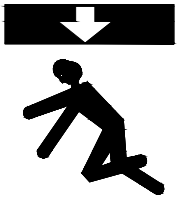

 **CAUTION:** Indicates a potentially hazardous situation which, if not avoided, may result in injury or property damage.

### **WARNING!**

A rolling door is a large heavy object that moves with the help of springs under extreme tension and electric motors. Moving objects and springs under tension and electric motors can cause serious injuries or death. For your safety and the safety of others, follow these instructions.

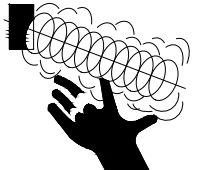
### **CAUTION**

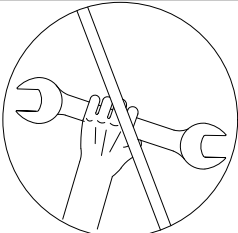
Use proper lifting equipment and correct lifting procedures to avoid damage or injury.

POTENTIAL HAZARD	EFFECT	PREVENTION
 <p>MOVING DOOR</p>	 <b>WARNING</b> Could result in death or serious injury	Keep people clear of opening while Door is moving. DO NOT allow children to play with the Door Operator. DO NOT operate a Door that jams or one that has a broken spring.
 <p>ELECTRICAL SHOCK</p>	 <b>WARNING</b> Could result in death or serious injury	Turn off power before removing operator cover. When replacing operator cover, make sure wires are not pinched or near moving parts. Operator must be properly grounded.
 <p>HIGH SPRING TENSION</p>	 <b>WARNING</b> Could result in death or serious injury	DO NOT try to remove, repair or adjust springs or anything to which Door spring parts are fastened, such as steel brackets or other like items. Repairs and adjustments must be made by a trained door system technician using proper tools and instructions.
	 <b>WARNING</b> Could result in death or serious injury	Door must be fully opened when making adjustments. Repairs and adjustments must be made by a trained rolling door systems technician using proper tools and instructions.

For All Fire Doors with 45 minute through 4 hour ratings

## ASTA America Chain Hoist Governor Installation Procedure

1. Inspect barrel and guide assembly for completeness of installation. (pg 3)
2. Install operator to the operator mounting plate and attach to headplate. (pgs 3 & 4)
3. Install and align sprockets and roller chain. (pg 5)
4. Install release devices, test handle and rig all cable assemblies. (pg 6)
5. Set up assembly for reliable drop testing. (pgs 7 & 8)
6. Demonstrate complete drop test procedure. (pg 9)

# ASTA America Series 500

## Chain Hoist Operator

### 1. Procedure for inspection of barrel and headplate assembly

- a. Verify that barrel is installed level.
- b. Verify that wall angle and guide assembly fasteners are secure.
- c. Verify that headplate bolts are in place and secure.

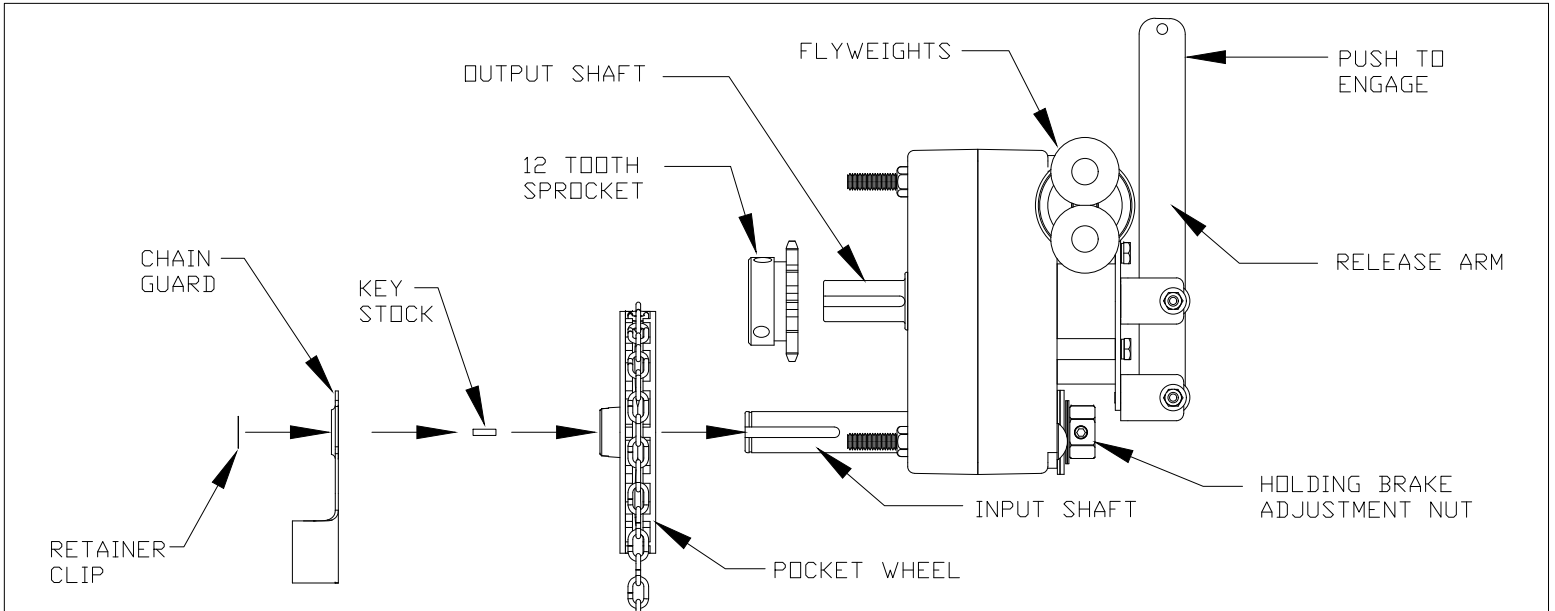

FIGURE 1

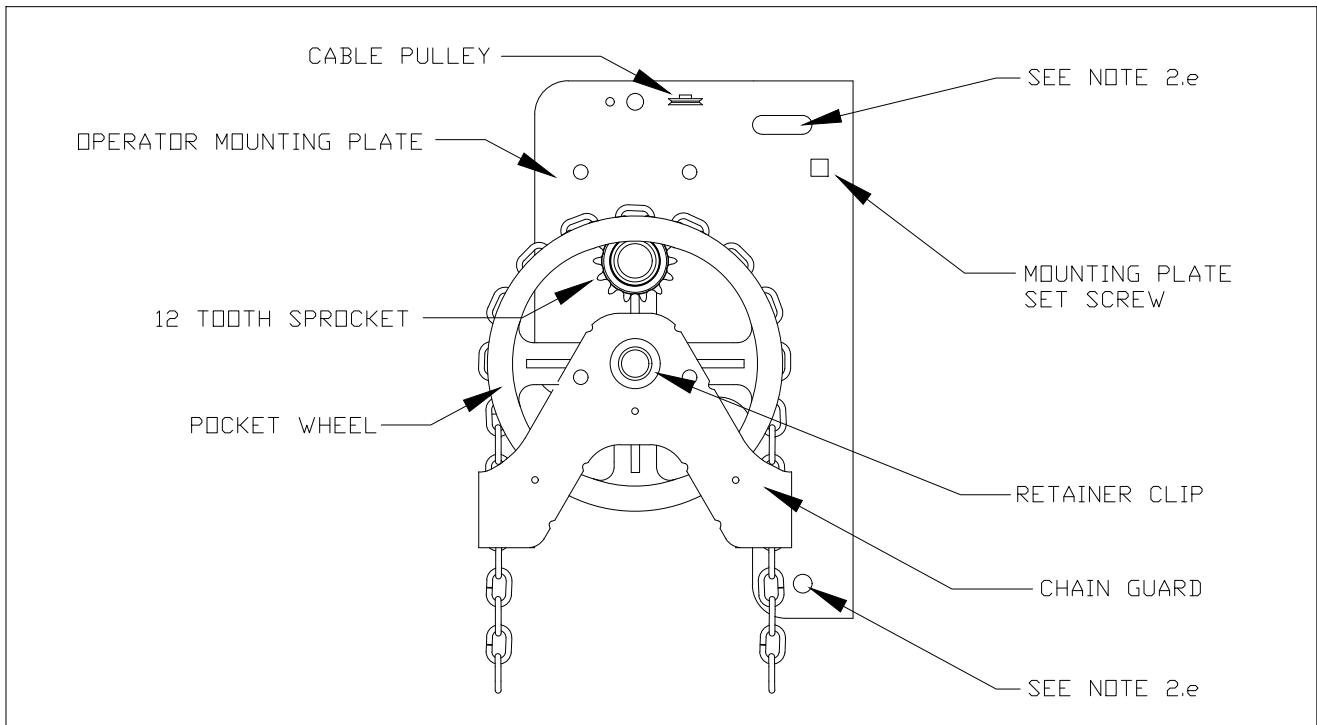

FIGURE 2

## 2. Procedure for installation of chain hoist operator

- a. Attach the operator to the mounting plate as shown in Figure 2 using four 3/8" nuts with lock washers.
- b. Install 12 tooth drive sprocket with key stock to output shaft shown in Figures 1 & 2.
- c. Install pocket wheel with key stock, followed by chain guard with retainer ring as shown in Figure 2.

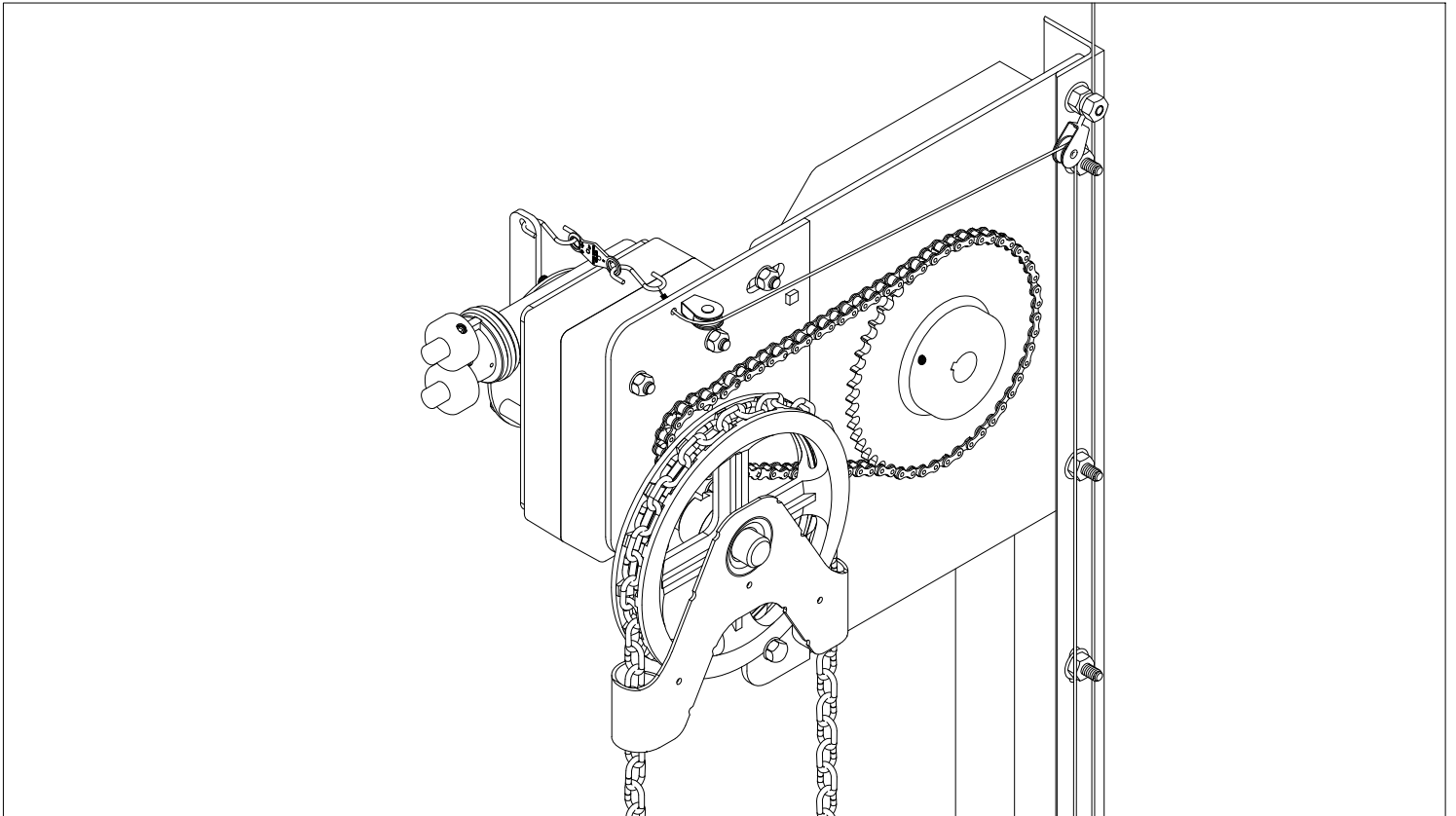

FIGURE 3

- d. Install hand chain making sure to keep it free of twists and kinks.
- e. Install the operator and bracket assembly to drive side headplate with two 1/2" x 1" carriage bolts as shown in Figure 3.
- f. Push operator assembly toward the wall as far as possible and temporarily secure the two carriage bolts.
- g. Install door drive shaft sprocket with key stock as shown in Figure 3.
  - ✓ Align the sprockets and tighten set screws.
  - ✓ Size and install supplied #50 roller chain to the two sprockets and secure roller chain with supplied master link.

- ✓ Loosen operator bracket bolts and tighten roller chain by pulling the assembly away from the wall, leaving approximately 3/4" overall slack in the roller chain.
- ✓ Tighten operator bracket carriage bolts and set screw securely to retain roller chain setting during future operation.

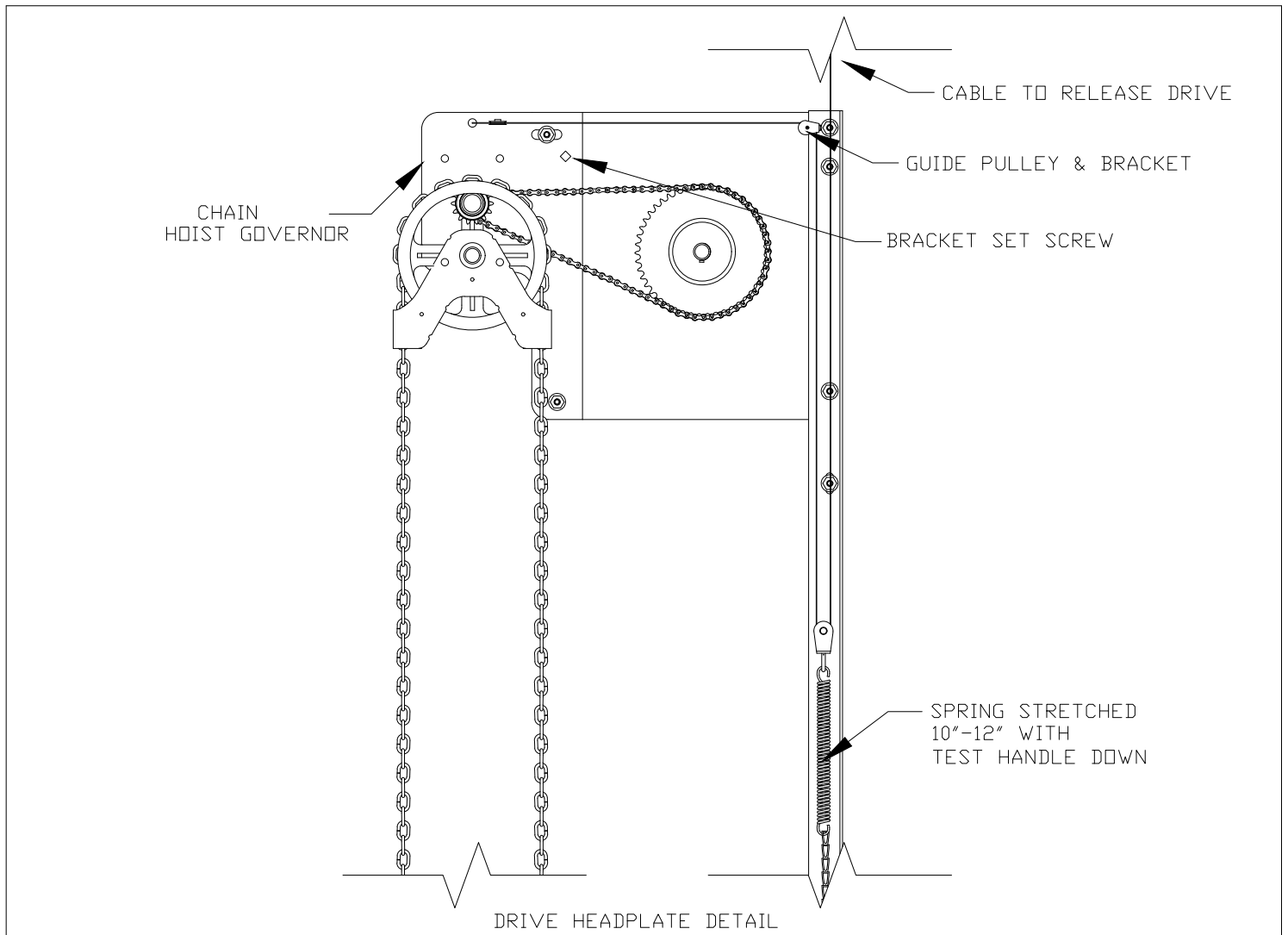

FIGURE 4

### 3. Procedure for rigging of disconnect cables and test handle

- a. Rig fusible links, disconnect cable, pulleys, spring and test handle as shown in Figure 4, above, in the base installation manual Appendix "A" and per NFPA-80.
- b. Rig cables so there is no slack present at any location, allowing a fully engaged position for both the release arm when test handle is down.
- c. The inline spring should stretch approximately 10" when the test handle is pulled to the downward position as shown in Figure 5.
- d. You should leave the chain hoist operator engaged with the test handle down for normal operation as shown in Figure 5.

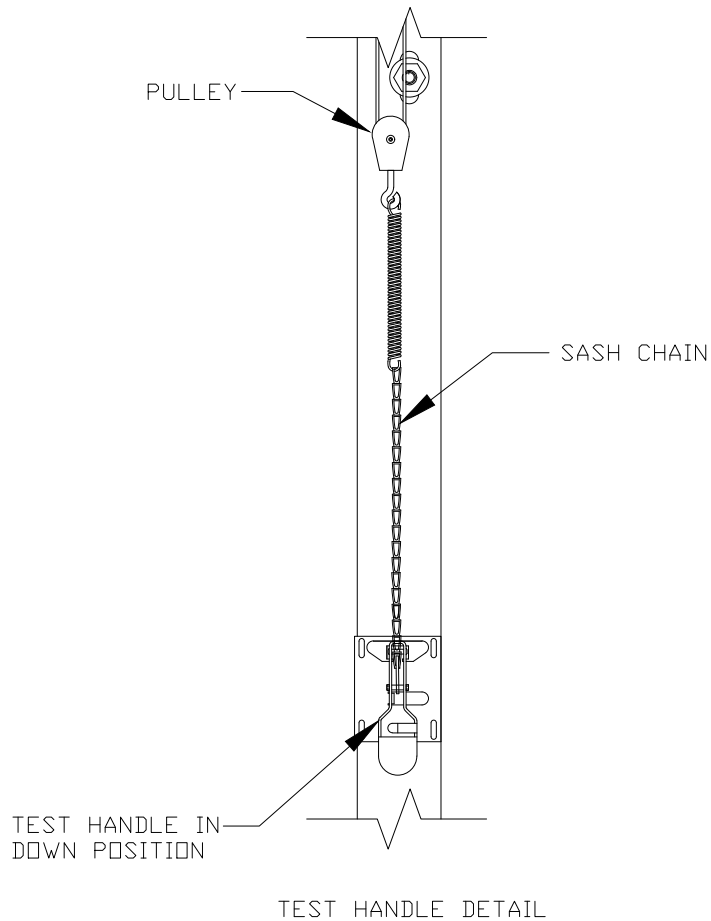
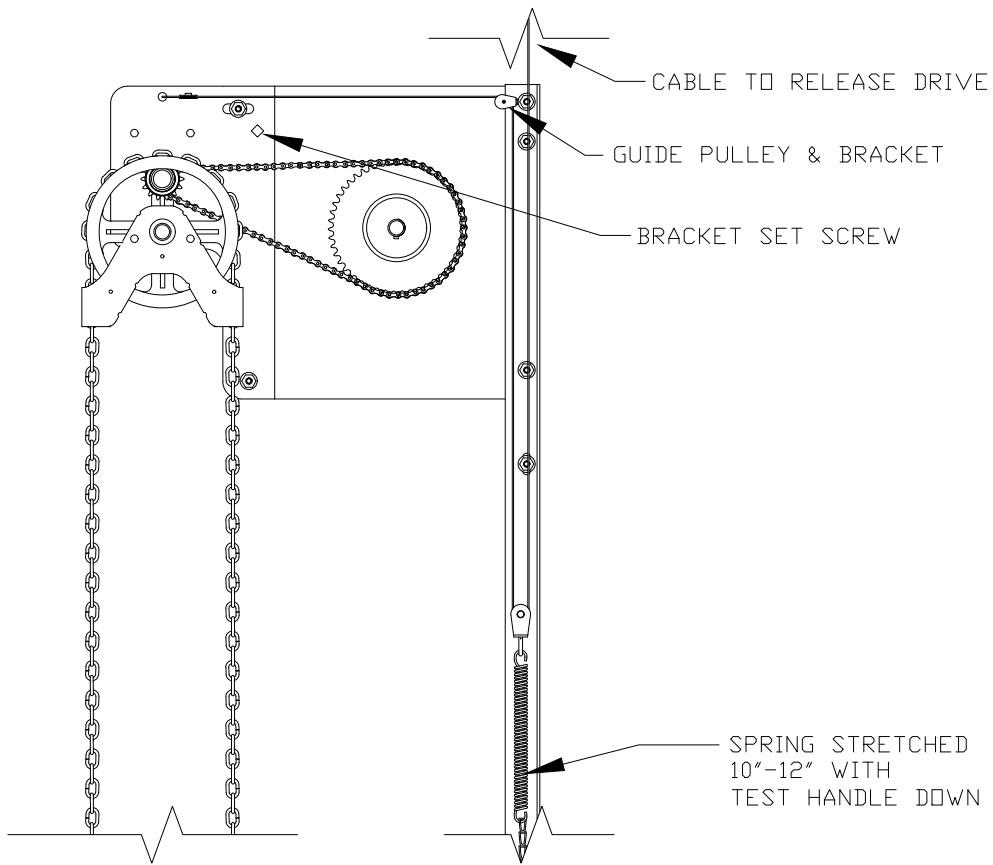

FIGURE 5

Note: You must put the door into an out-of balance condition at this time to proceed with drop testing. Refer to Appendix B of the base installation manual to perform this step before going further.

Note: With the door in an out-of-balance condition, the curtain should remain in the fully open position without drifting downward when the test handle is engaged. If it does not, follow instructions in step 4 below.

#### 4. Procedure for adjustment of holding brake

- a. Loosen the set screw on the holding brake adjustment nut as shown in Figure 1.
- b. Tighten the holding brake adjustment nut enough to prevent the curtain from drifting downward from the head stops.
- c. Tighten set screw and check curtain.

### DROP TEST SETUP AND ADJUSTMENT FOR ASTA CHAIN HOIST GOVERNOR

**IMPORTANT EXPLANATION:** Upon release of the test handle, or other activation of the door, the chain hoist operator allows the curtain to move in the downward direction and establish momentum. Door descent speed is limited, or governed, by means of a centrifugal brake.

Note: Final drop tests must be initiated with the door in the fully open position. You may drop test the ASTA Door chain hoist operated fire door from any position without harm to the door or operator. If you wish to initiate your first release and drop with the door close to the floor to familiarize yourself with closing speed and governor function, you may do so before completing a full height test drop. Proceed with step 5 to perform the drop test.

#### 5. Procedure for drop testing the fire door assembly

- a. Clear the area in the path of the closing door.
  - b. Use a barricade to halt traffic through the opening.
  - c. Raise door to the fully open position.
  - d. Release test handle and initiate the drop test.
  - e. Curtain and bottom bar should descend downward in a controlled manner to rest on the floor.
- ✓ The closing speed of the curtain must be set to between 6" per second and 24" per second per manufacturers design and per NFPA-80.



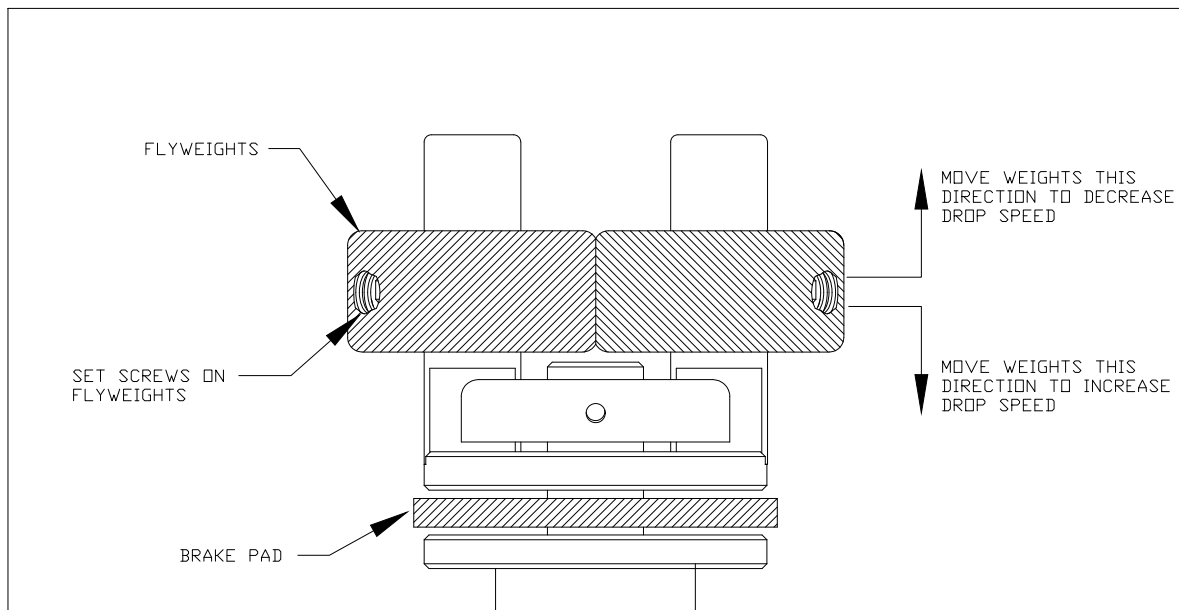

FIGURE 7

## 6. Fine Tuning the descent speed of the door

- a. To slow drop speed of the curtain, adjust flyweights outward, away from the brake pad as shown in Figure 7.
- b. To increase drop speed of the curtain, adjust flyweights inward, toward the brake pad as shown in Figure 7.

## FINAL DROP TESTING INSTRUCTIONS

1. Clear the area in the path of the closing door.
2. Use a barricade to halt traffic through the opening.
3. Raise door to full open position. Drop test the door using the appropriate supplemental operator installation instructions for this installation.
4. An average curtain closing speed of between 6" to 24" per second is required per manufacturers design, and per NFPA-80, 2007 Edition.
  - a. Refer to the appropriate supplemental operator installation instructions to adjust closing speed.
5. Complete all instructions and required information on Drop Test Form and apply date.
6. Demonstrate complete Drop Test and Reset procedure to the Witness a minimum of two times per NFPA-80.
7. Witness should be one of the following:
  - b. Authority Having Jurisdiction
  - c. Owner or Owners Representative
  - d. Jobsite Contractor
8. Obtain the Witness signature on enclosed Drop Test Form.
9. Leave copy of completed and signed Drop Test Form and copy of Base Fire Door Installation Manual and Supplemental Manual with Owners Representative or Contractor.

# NOTES

**FIRE DOOR 500 SERIES  
CHAIN HOIST GOVERNOR  
INSTALLATION MANUAL**



**ASTA** **AMERICA**

---

**BY JANUS INTERNATIONAL**

**638 Cassville White Rd NW  
Cartersville, GA 30121  
P.O. Box 639  
Cassville, GA 30123**

**Office: 770-974-2600  
Fax: 770-974-1455  
[www.ASTAAmerica.com](http://www.ASTAAmerica.com)**