

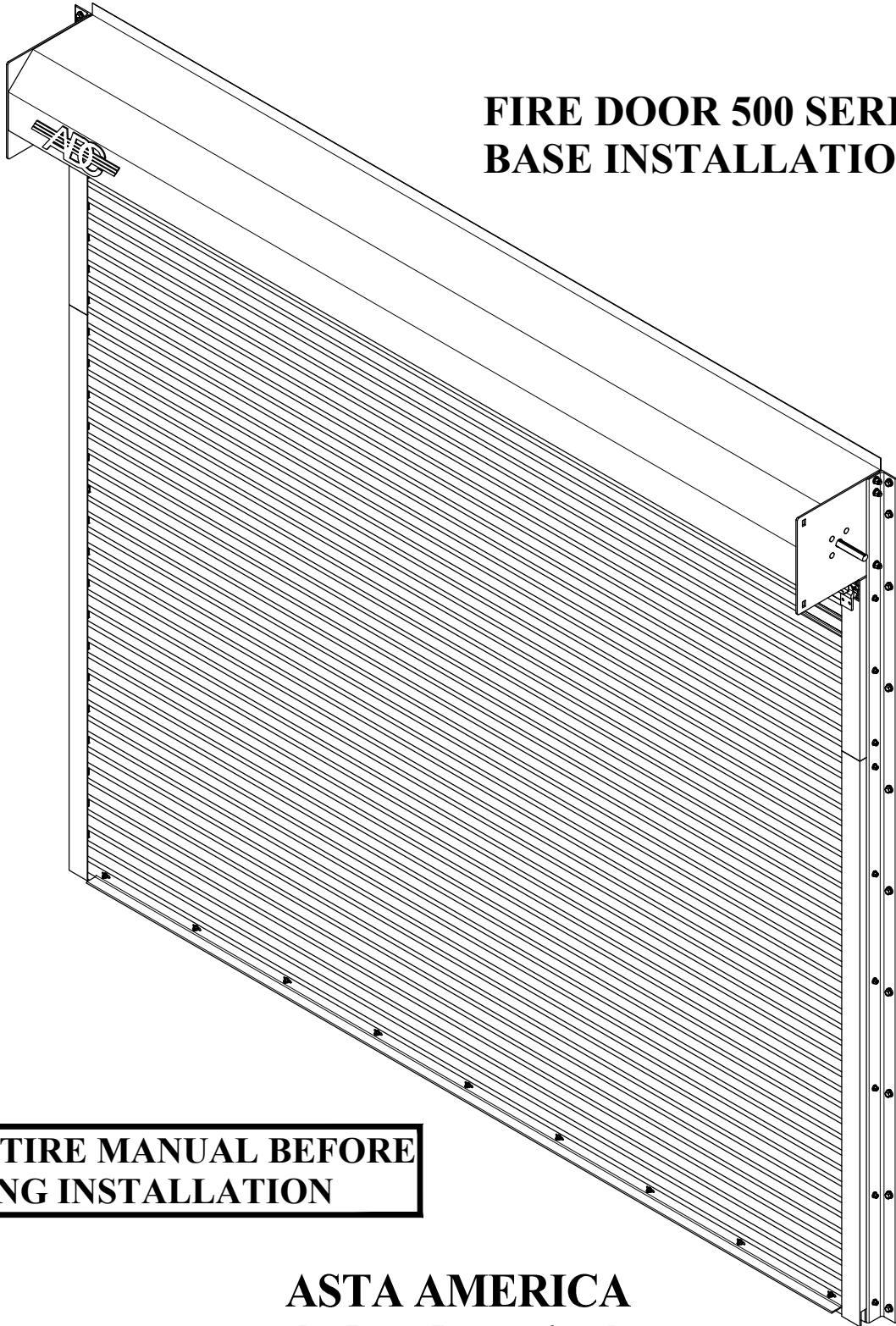

ASTAAMERICA

BY JANUS INTERNATIONAL

**FIRE DOOR 500 SERIES
BASE INSTALLATION MANUAL**



**READ ENTIRE MANUAL BEFORE
BEGINNING INSTALLATION**

ASTA AMERICA

by Janus International

CARTERSVILLE, GA

astaamerica.com

DECEMBER 2020

SAFETY INFORMATION

OVERVIEW OF POTENTIAL HAZARDS

Overhead doors are large, heavy objects that move with the help of springs under high tension and electric motors. Since moving objects, springs under tension, and electric motors can cause injuries, your safety and the safety of others depend on you reading the information in this manual. If you have questions or do not understand the information presented, call your nearest service representative.

In this section, and those that follow, the words "Danger", "Warning", and "Caution" are used to emphasize important safety information. For example:

 **DANGER:** Indicates an imminently hazardous situation which, if not avoided, will result in death or serious injury.

 **WARNING:** Indicates a potentially hazardous situation which, if not avoided, could result in death or serious injury.







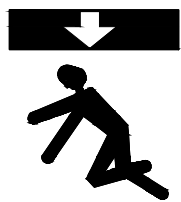

 **CAUTION:** Indicates a potentially hazardous situation which, if not avoided, may result in injury or property damage.

WARNING!

A rolling door is a large heavy object that moves with the help of springs under extreme tension and electric motors. Moving objects and springs under tension and electric motors can cause serious injuries or death. For your safety and the safety of others, follow these instructions.

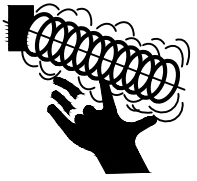
CAUTION

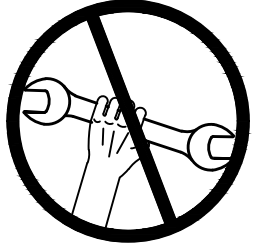
Use proper lifting equipment and correct lifting procedures to avoid damage or injury.

POTENTIAL HAZARD	EFFECT	PREVENTION
 <p>MOVING DOOR</p>	 WARNING Could result in death or serious injury	Keep people clear of opening while Door is moving. DO NOT allow children to play with the Door Operator. DO NOT operate a Door that jams or one that has a broken spring.
 <p>ELECTRICAL SHOCK</p>	 WARNING Could result in death or serious injury	Turn off power before removing operator cover. When replacing operator cover, make sure wires are not pinched or near moving parts. Operator must be properly grounded.
 <p>HIGH SPRING TENSION</p>	 WARNING Could result in death or serious injury	DO NOT try to remove, repair or adjust springs or anything to which Door spring parts are fastened, such as steel brackets or other like items. Repairs and adjustments must be made by a trained door system technician using proper tools and instructions.
	 WARNING Could result in death or serious injury	Door must be fully opened when making adjustments. Repairs and adjustments must be made by a trained rolling door systems technician using proper tools and instructions.

TYPICAL FIRE DOOR

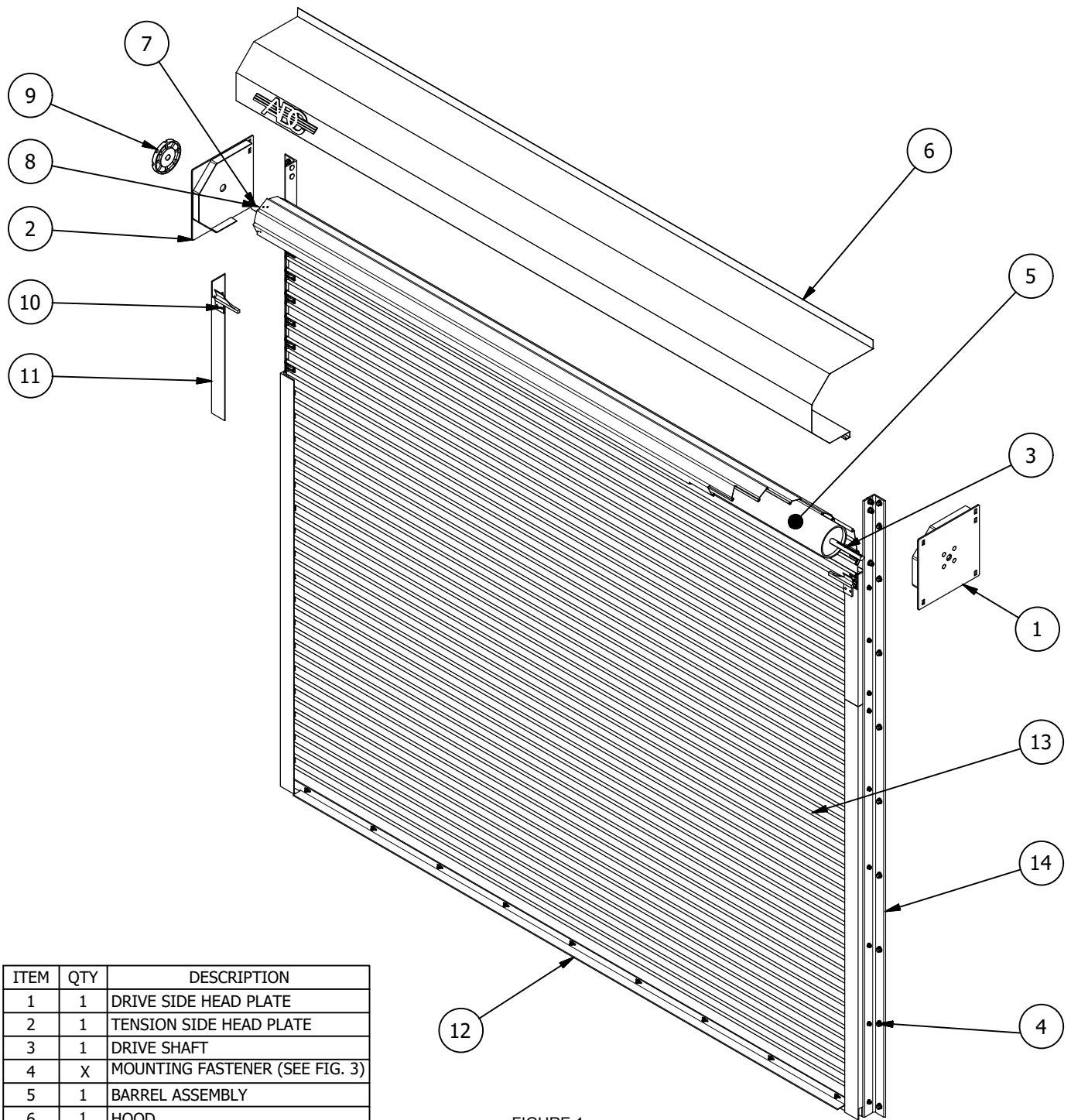

FIGURE 1

ITEM	QTY	DESCRIPTION
1	1	DRIVE SIDE HEAD PLATE
2	1	TENSION SIDE HEAD PLATE
3	1	DRIVE SHAFT
4	X	MOUNTING FASTENER (SEE FIG. 3)
5	1	BARREL ASSEMBLY
6	1	HOOD
7	1	TENSION SHAFT
8	1	PVC SPACER
9	1	TENSION WHEEL
10	2	BELLMOUTH/HEADSTOP
11	2	SERVICE CUT-OUT
12	1	BOTTOM BAR ASSEMBLY
13	1	CURTAIN ASSEMBLY
14	2	GUIDE ANGLE ASSEMBLY

RH Drive Shown
LH Drive Opposite

GUIDE MOUNTING DETAILS

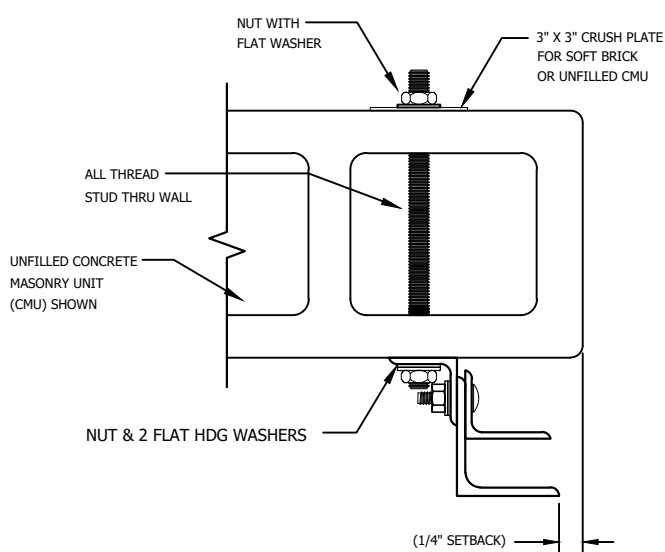

FIGURE 2.A

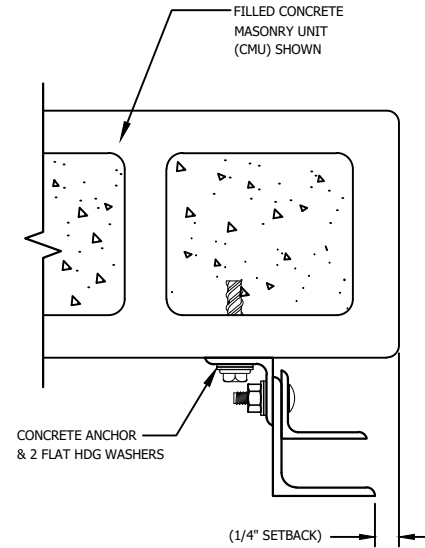

FIGURE 2.B

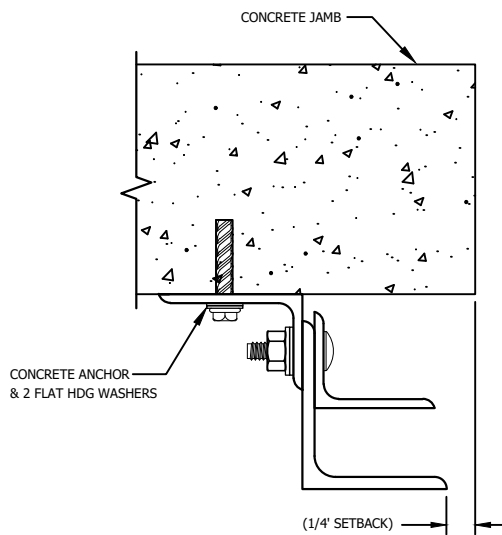

FIGURE 2.C

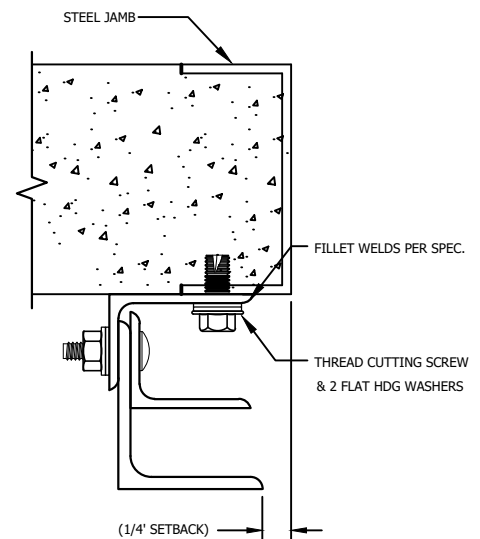

FIGURE 2.D

FIGURE 2

FASTENER CHART

JAMB	FASTENER	DRILL SIZE	NOTES
STEEL	3/8-16 X 1" TYPE 23 THD CUT SCREW	11/32"	3/16" THICK STEEL JAMB MINIMUM
	3/8-16 X 1-1/4" HEX BOLT AND NUT	7/16"	
	1/2-13 X 1-1/4" TYPE F THD CUT SCREW	29/64"	
	1/2-13 X 1-1/2" HEX BOLT AND NUT	9/16"	
CONCRETE OR FILLED BLOCK	3/8" X 4" DEWALT SCREW-BOLT+	3/8" ANSI B212.15	CLEAR HOLES OF CONCRETE DUST BEFORE INSTALLING FASTENER
	1/2" X 3" DEWALT SCREW-BOLT+	1/2" ANSI B212.15	
UNFILLED BLOCK OR SOFT BRICK	3/8" THREADED ROD & NUTS	7/16"	INSTALL CRUSH PLATES ON OPPOSITE SIDE OF WALL
	1/2" THREADED ROD & NUTS	9/16"	

FIGURE 3

1. Pre-Installation Evaluation

- a. Verify that your measurements match the opening width, height, headroom, sideroom and backroom dimensions shown on shop drawing.
- b. Verify that jamb construction is the same as shown in shop drawing and that construction is suitable for mounting guides.
- c. Verify that guides can be mounted plumb.
- d. Verify that all door parts are available.

2. Procedure for laying out guides

- a. Find and mark centerline of opening and mark as shown in Figure 5.
- b. Determine "W" dimension from the table in Figure 5.
- c. Center "W" dimension on floor using center line of opening, and clearly mark floor at each jamb.
- d. Jamb floor marks should precisely equal "W" dimension and reflect the location of the wall angle's perpendicular leg as shown in Figure 5.

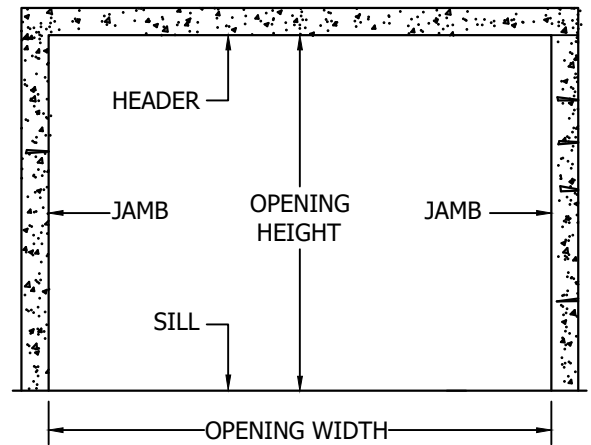
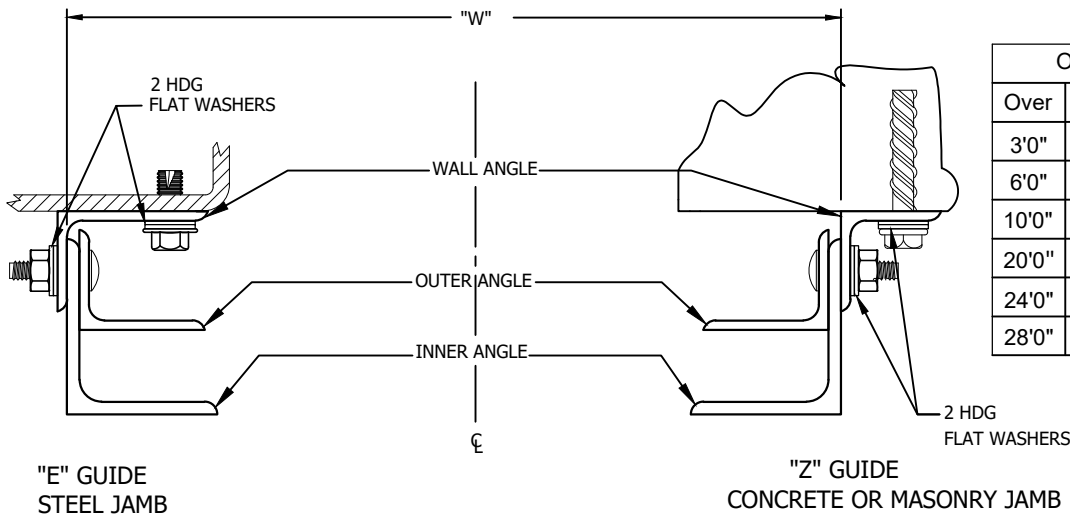

FIGURE 4



Opening Width		W Dimension
Over	Up To & Including	
3'0"	6'0"	Opening Width + 5-1/2"
6'0"	10'0"	Opening Width + 6-1/2"
10'0"	20'0"	Opening Width + 8-1/2"
20'0"	24'0"	Opening Width + 9"
24'0"	28'0"	Opening Width + 11"
28'0"	32'0"	Opening Width + 13-1/8"

STRUCTURAL ANGLE GUIDES - FACE OF WALL

FIGURE 5

3. Procedure for shooting level reference marks

- a. Create level elevation marks at left and right jamb faces using a level reference device or survey instrument as shown in Figure 6.

✓ Be positive about the accuracy of your level elevation reference marks!

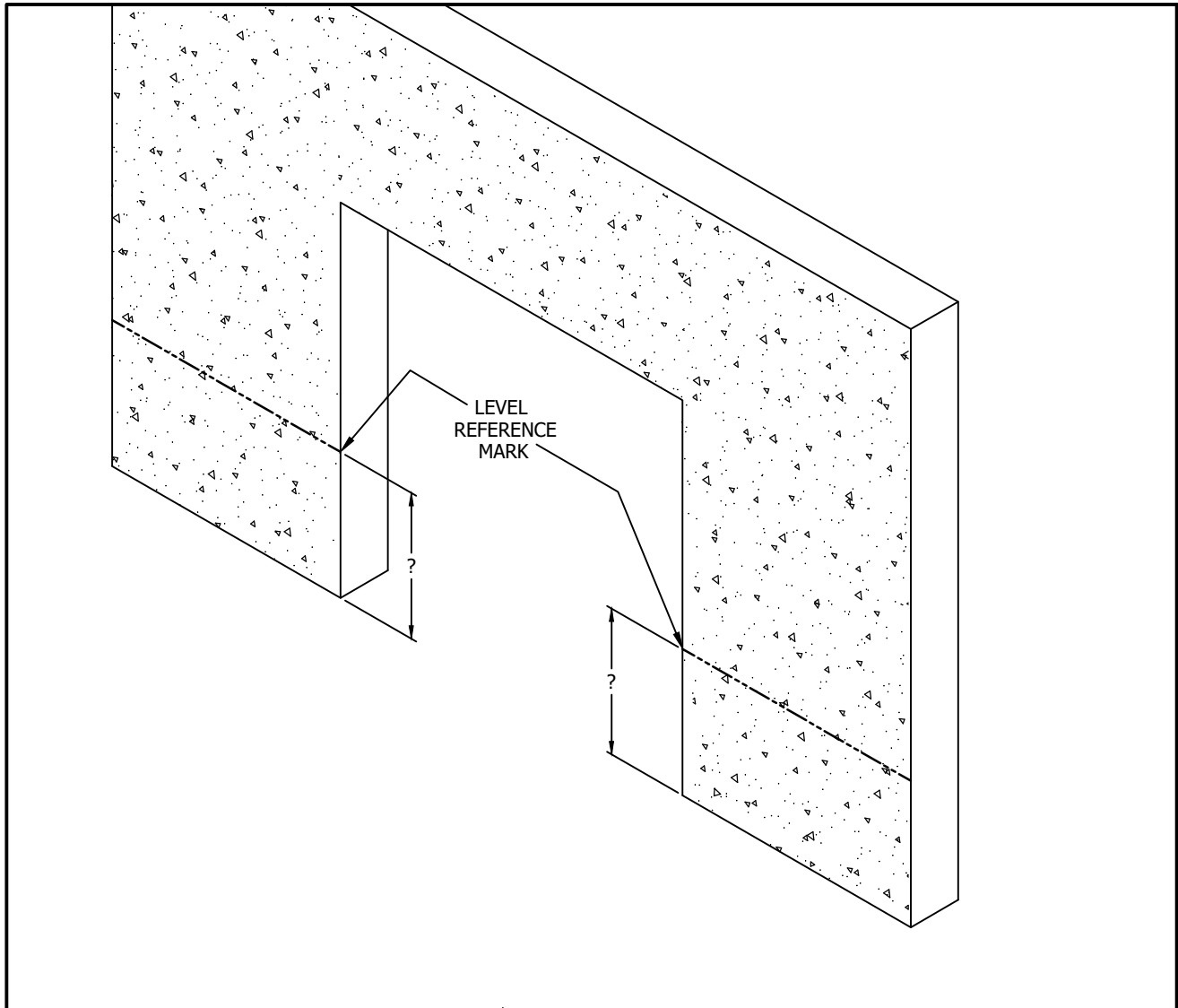

FIGURE 6

- b. Measure the distance from each level reference mark to the floor to determine if the floor is level.

✓ If there is a difference in measurements from the marks to the floor, the floor is not level. You must shim the wall angle with the longest reference measurement to verify that both wall angles are mounted to the same elevation.

NOTE: Use only fasteners provided and approved by ASTA Door Corporation. Reference Figure 3 to determine correct jamb fastener type for your application, and for drill bit size, etc. Locate wall angle masonry anchors or machine screws in the TOP of each slot as shown in Figure 7.

IMPORTANT

NOTE: It is the manufacturers intent that E-type guides be disassembled prior to installation for attachment by machine screws, masonry anchors or weldments.

NOTE: Wall angles may extend above steel jambs onto masonry. In this case, attach with masonry anchors of size and type recommended by manufacturer. Mount in the top of each slot as shown in Figure 7. Shim with washers as required to maintain a flush mounting surface for the wall angle. Use anchors that match the diameter of headplate bolts.

- ✓ Two hot dipped galvanized washers must be installed under the head of each jamb fastener as shown in Figure 7.
- ✓ USE ONLY HOT DIPPED GALVANIZED WASHERS PROVIDED BY ASTA. DO NOT SUBSTITUTE WASHERS OF ANY OTHER TYPE OR SOURCE!

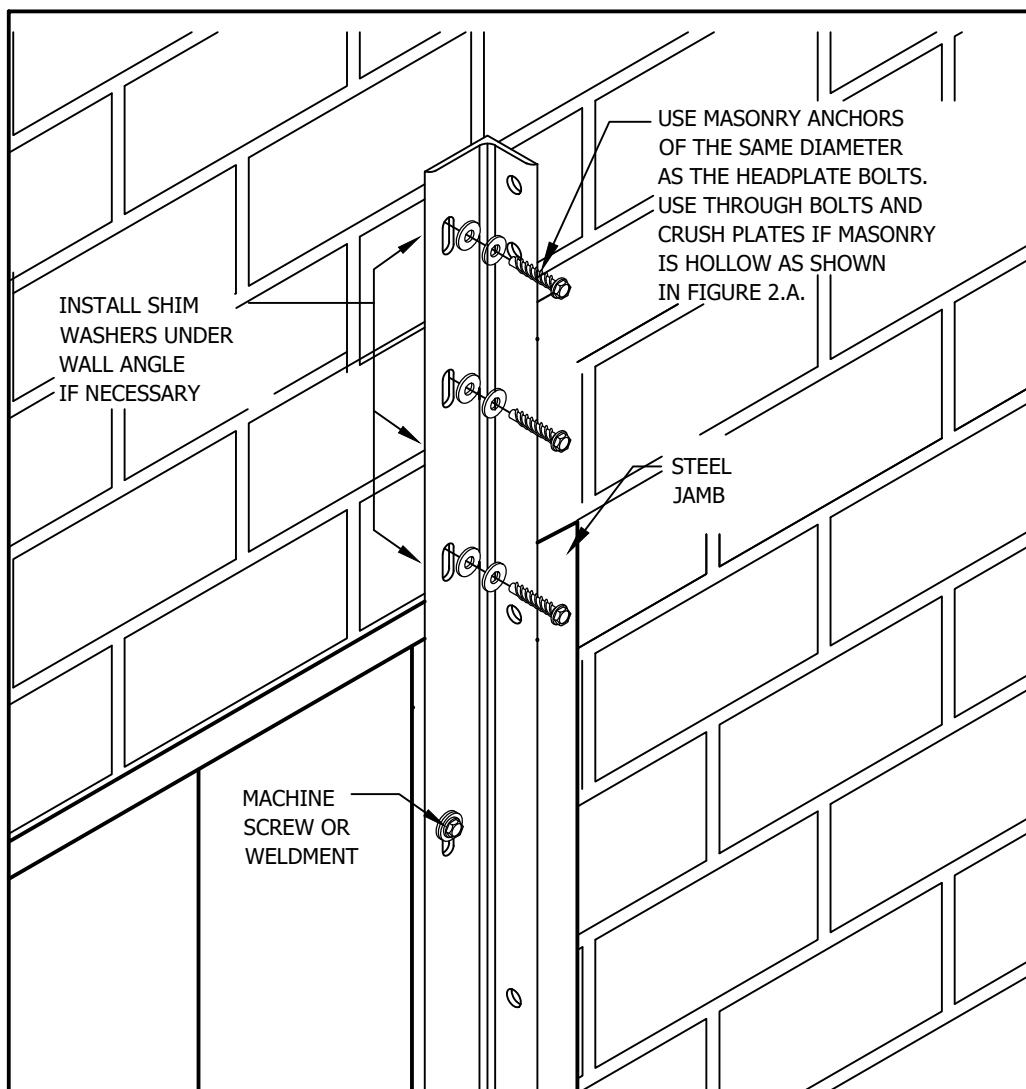

FIGURE 7

NOTE: Procedure for welding wall angles to steel jambs.

- ✓ Create weldments consistent only with the specifications shown in Figures 8 and 9.

FACE WALL MOUNT SHOWN

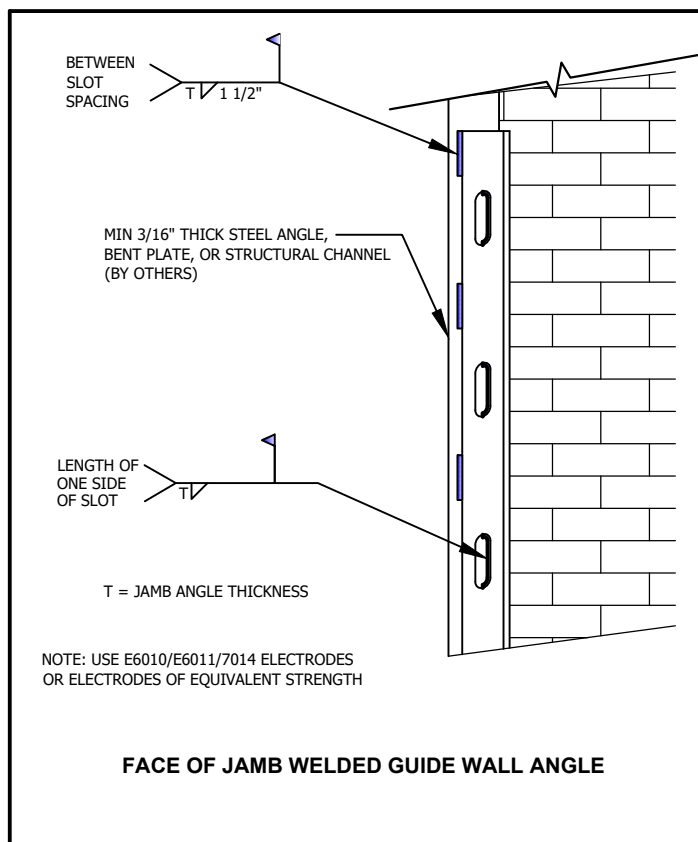

FIGURE 8

BETWEEN JAMBS MOUNT SHOWN

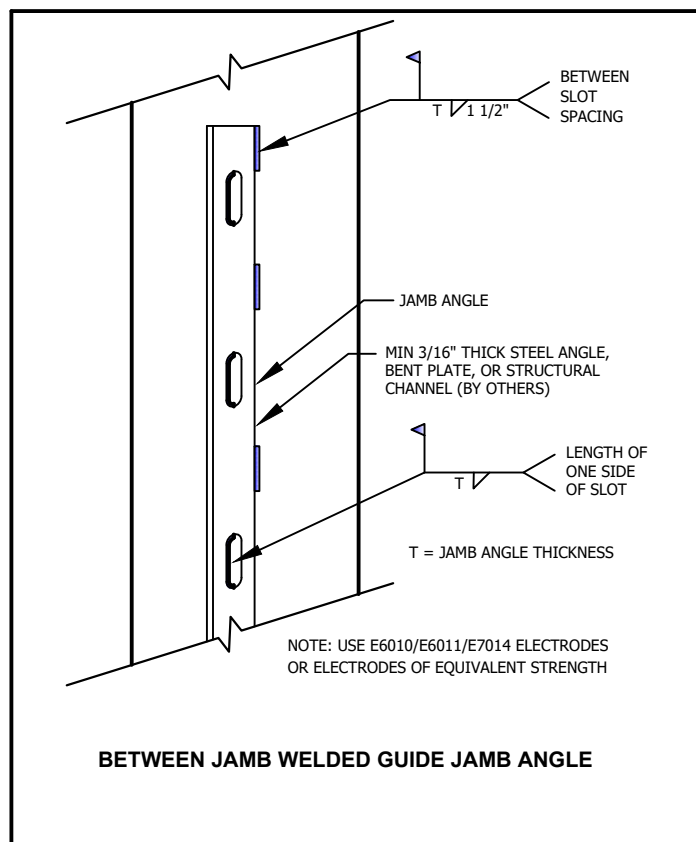

FIGURE 9

- ✓ This is an upward expanding fire door. Guide angles are designed to be set upon the floor unless one angle requires the use of steel shims at the floor level to create level guide elevations as shown in Figure 10.
- ✓ Verify that the low side wall angle is shimmed to the correct height before permanent attachment to the jamb.

4. Procedure for installing wall angles

- Use a plumb bob or level reference device to establish a true plumb reference.
- Install first wall angle plumb vertically at the correct elevation, and at the correct "W" dimension floor mark.
- Install second wall angle by placing it at the "W" dimension marked on the floor at the second jamb as shown in Figure 10. Shim if necessary.

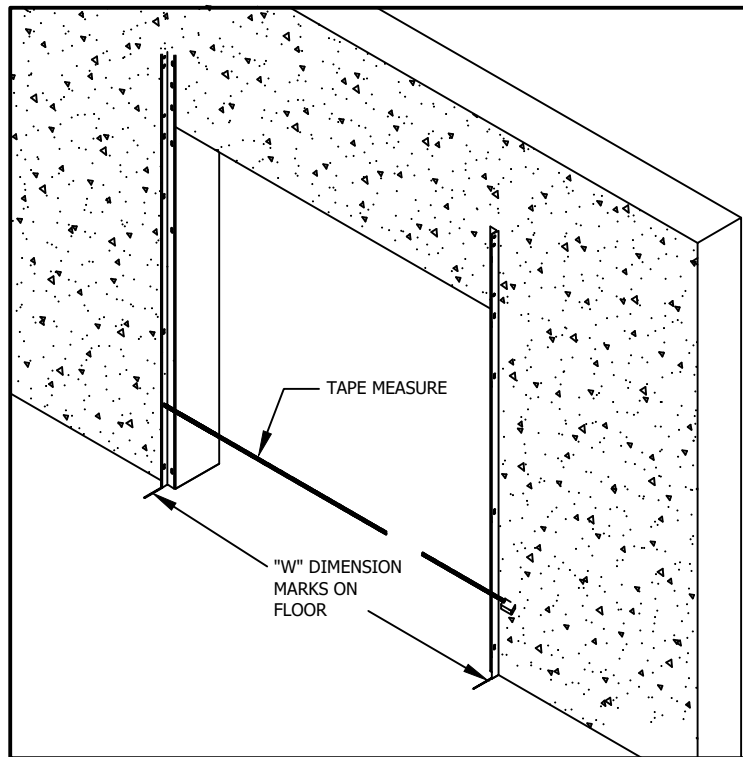

FIGURE 10

- d. Use a tape measure while attaching the second wall angle to maintain a consistent "W" dimension all the way to the top as shown in Figure 10.
6. Procedure for installing guide angle fasteners
 - a. Use two hot dipped galvanized washers under each nut as shown in Figure 11.
 - b. Install the head stops to the service cut-outs. See Figure 17.
 - c. Do not install guide angle service cut-outs at this time.

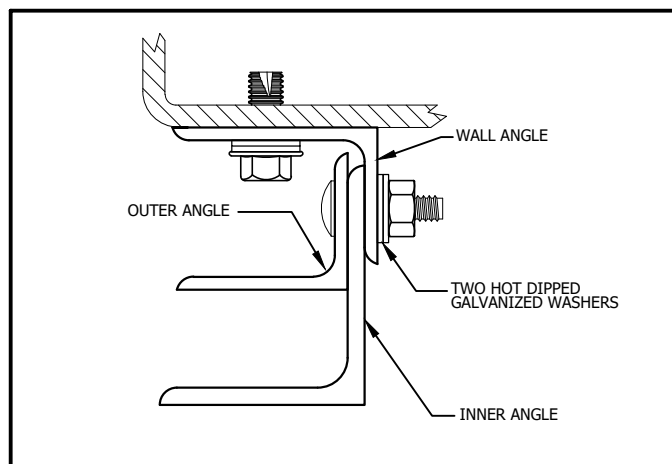

FIGURE 11

7. Procedure for installing barrel and headplate assemblies to wall angles

a. Proceed at ground level and identify components as shown in Figures 12 and 13.

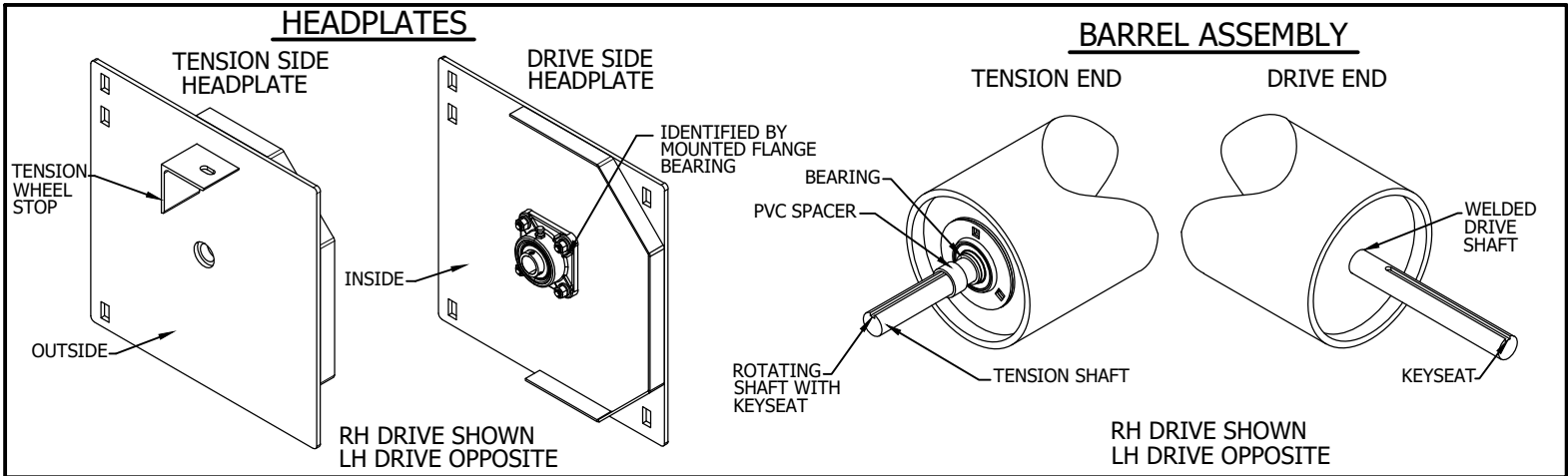

FIGURE 12

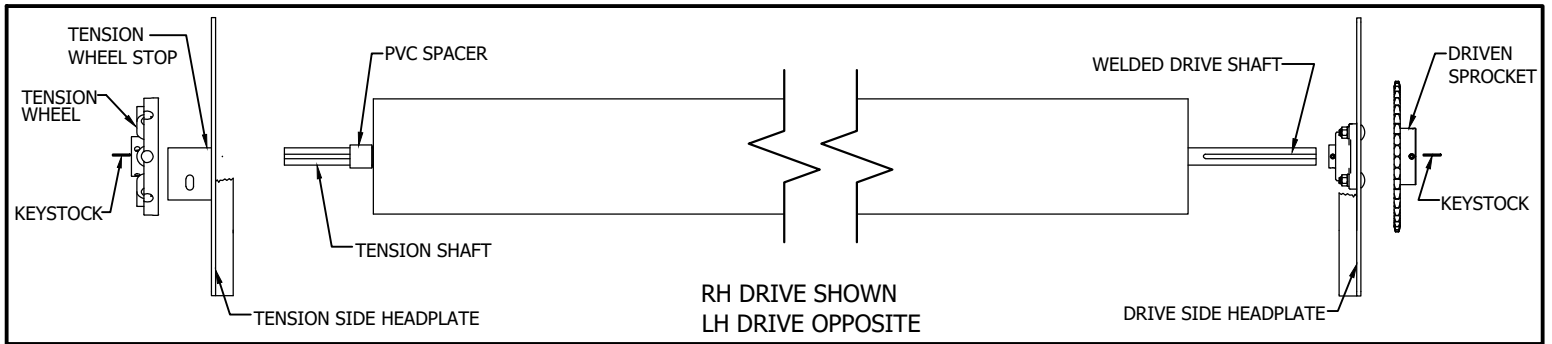

FIGURE 13

- b. Install drive side headplate with mounted bearing as far as possible onto drive shaft. Install sprocket and keystock onto drive shaft and tighten set screws on sprocket at this time as shown in Figure 13.
- c. Install PVC spacer, headplate, tension wheel and keystock on Tension Shaft as shown in Figure 14. Tighten set screws on Tension wheel.

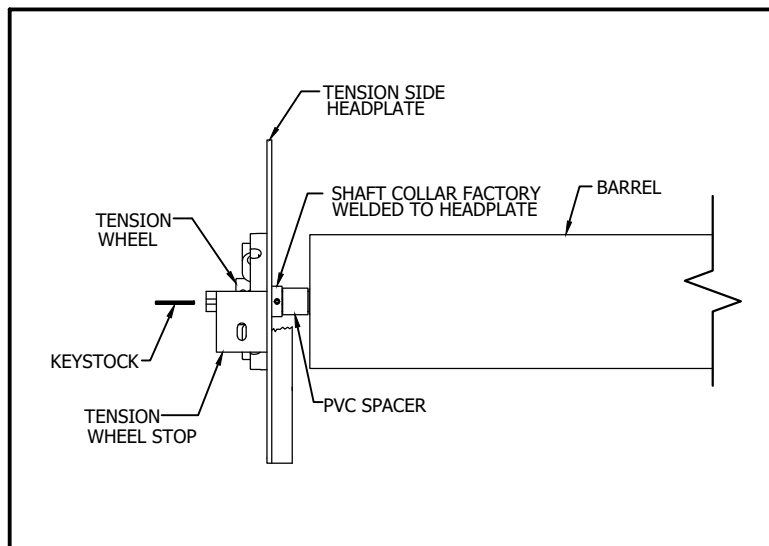

FIGURE 14

8. Procedure for installing barrel and headplates to guide assembly

- a. Carefully secure barrel to hoisting equipment and raise into position at top of wall angles. Attach headplate brackets to inside of wall angles as shown in Figure 15.
- b. **VERIFY THAT BARREL IS DEAD LEVEL BEFORE TIGHTENING HEADPLATE BOLTS!**
- c. Verify that barrel is unrestricted and free to rotate before proceeding.

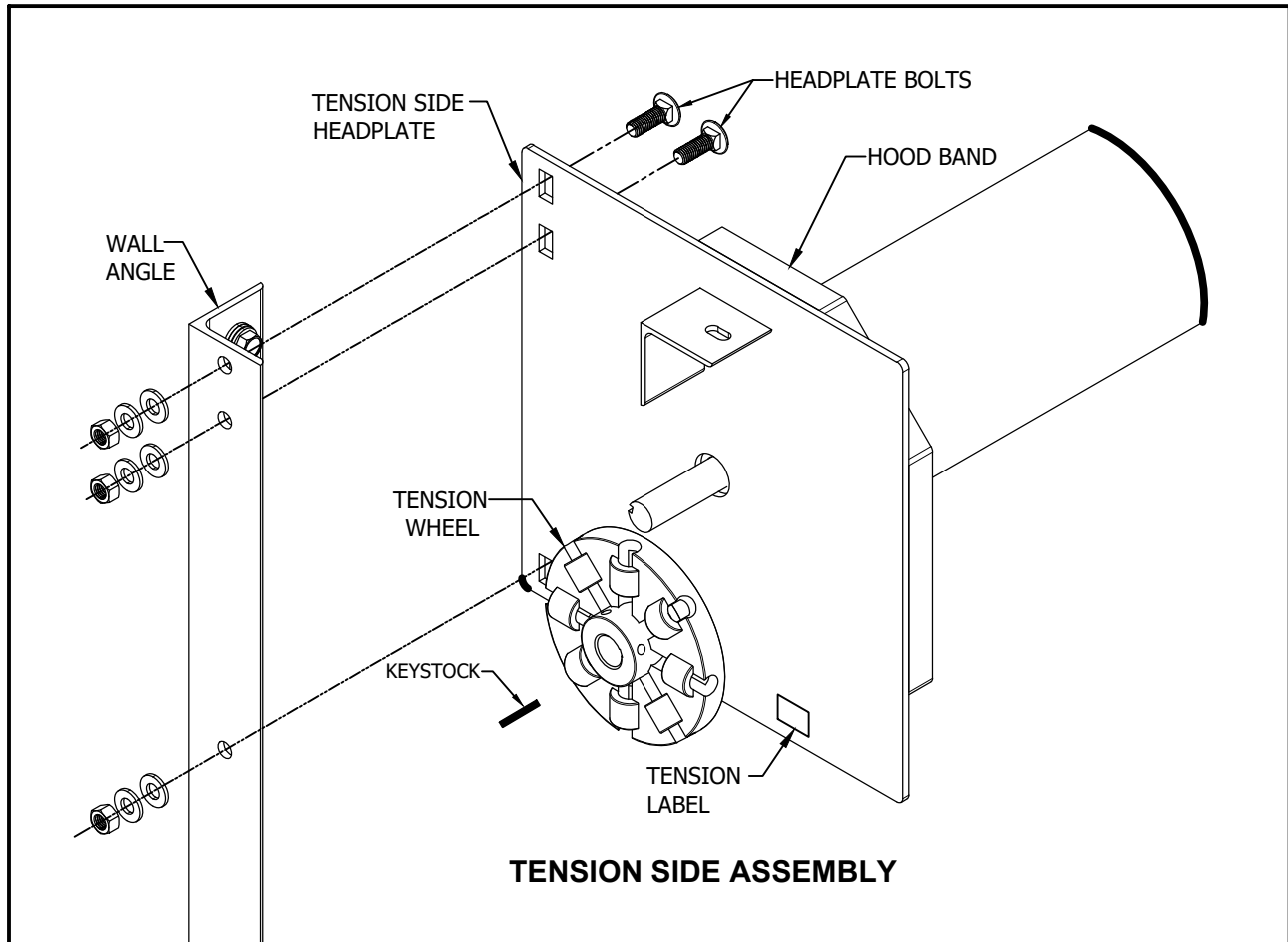

FIGURE 15

⚠ WARNING

Use proper lifting equipment and correct lifting procedures. Failure to do so could result in death or serious injury.

NOTE: At this time, you may refer to the specific operator instructions provided to install the operator bracket, operator, test handle and cable assemblies.

- ✓ Refer to the Appendix "A" for related fusible link and cable routing drawings.
- ✓ Refer to the Appendix "C" & the provided owners manual for motor operators.

SLINGING: IMPORTANT SAFETY PRECAUTIONS

Use only straight-eye choker style slings with a minimum 5,000 lb weight rating.

Use slings of a length that keeps the factory rolled curtain as close to the barrel assembly as possible.

Close and secure sling ends with a clevis or chain shackle of adequate size that features a SCREW-IN STYLE PIN ONLY. DO NOT USE A CLIP RETAINED SHACKLE OR CLEVIS PIN!!

9. Procedure for slinging curtain to barrel

- a. Using hoisting equipment, suspend the curtain assembly below the barrel on two or more slings.
- b. Center the factory rolled curtain assembly between guides in the service cutout portion of the guide assembly as shown in Figure 16.
- c. Use locking pliers to temporarily fasten two or more segmented starter slats to slings.
- d. Roll curtain, slings and barrel as one unit in order to pull the starter slats and curtain over the top of the barrel.
- e. Attach segmented starter slats to barrel using ASTA Door Corporation supplied cap head screws and remove locking pliers.

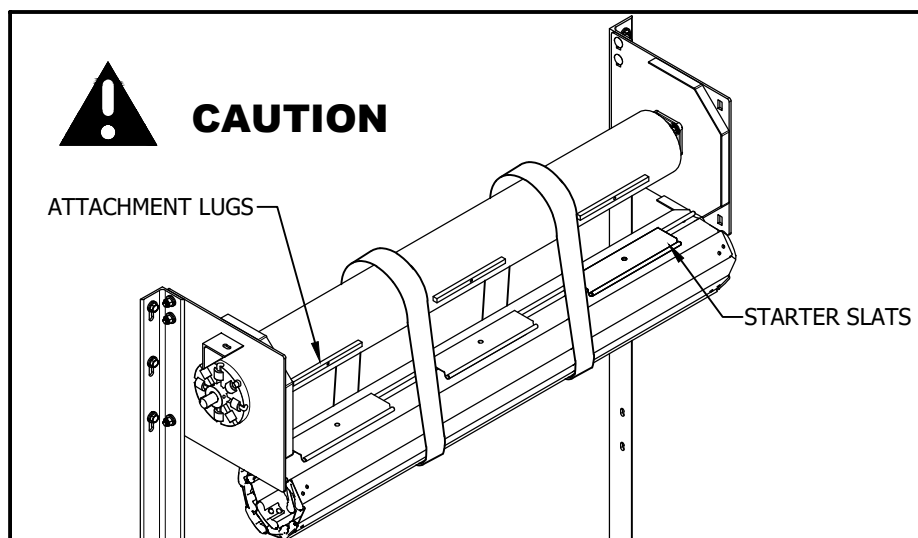

FIGURE 16

- ✓ It may be necessary to use the hoisting equipment to lift the weight of the curtain enough to allow rotation of the barrel to bring the attachment barrel lugs into position with segmented starter slats.
 - ✓ When starter slats are attached to the barrel lugs, you may lower the hoisting equipment and proceed with the next step.
- f. Center curtain slats individually between the guide throats as you slowly rotate the barrel and roll the curtain onto the barrel.
 - g. Transfer the entire curtain assembly onto the barrel, but leave the bottom bar hanging 3"-4" below the head stop location.
 - h. Secure curtain at this time to prevent downward rotation.

- i. Install guide service cutouts with previously installed head stops as shown in Figure 17.
- j. Tighten guide assembly fasteners securely with two hot dipped galvanized washers per bolt as shown in Figure 11.

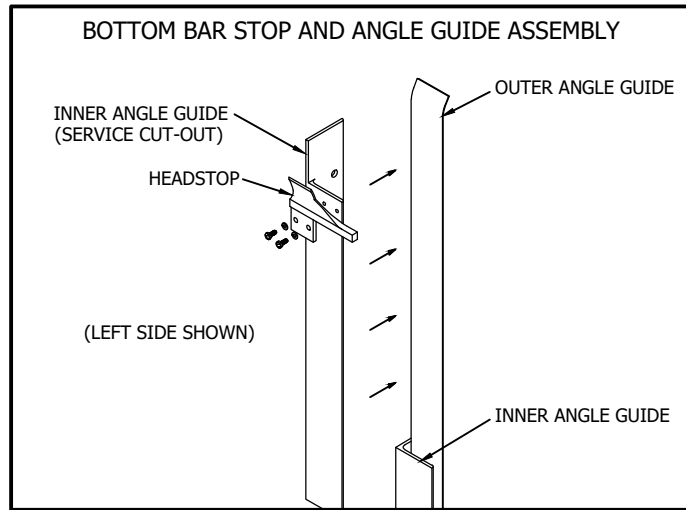

FIGURE 17

**USE ONLY HOT DIPPED GALVANIZED WASHERS PROVIDED BY ASTA.
DO NOT SUBSTITUTE WASHERS OF ANY OTHER TYPE OR SOURCE!**

- 10. Procedure for applying tension preload to barrel assembly
 - a. Install locking pliers to service cutouts approximately 4" down from head stops to arrest any downward curtain travel as shown in Figure 18.
 - b. Release and lower the curtain to rest slack upon the locking pliers. Barrel should be free to rotate at this time.
 - c. Apply tension from the top, downward, as shown in Figure 18 to the preload amount shown on tension label and on barrel sticker.

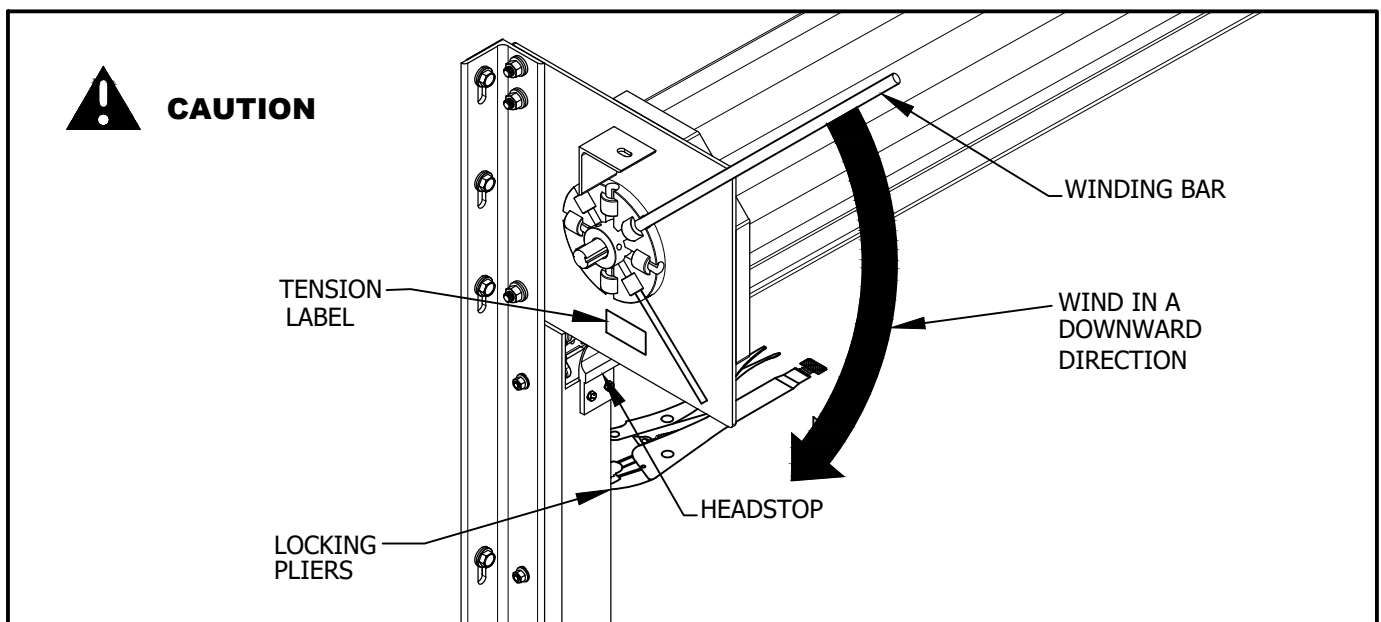

FIGURE 18



WARNING: Use two solid steel winding bars of a diameter matching the tension wheel lugs. Use of undersized or non-solid steel winding bars will result in component failure, injury, or death.

- d. Bottom bar should rise from locking pliers and come to rest touching head stops when full preload tension has been applied.
- e. Insert tension wheel pin as shown in Figure 20.
- f. You may now remove slings.

11. Procedure for checking correct operation

NOTE: You must re-engage test handle or operator at this time to allow operation of the door.

- a. Clear the doorway and closing path of the door.
- b. Lower and raise the door several times.
- c. Inspect curtain to certify that the endlocks or windlocks at each end of the curtain are centered and do not rub on the headplates.
- d. Make any necessary tension adjustments, hoist adjustments or operator limit adjustments in order to achieve reliable operation and complete range of travel with no binding or dragging.
- e. Verify that all fasteners are correctly installed and secured tightly.
- f. Attach the product safety labels as directed on labels.
- g. Apply sensing edge warning label if applicable.

Important Notes for a correctly balanced and functional door:

- ✓ The bottom bar must fully rest on the floor when in the closed position.
- ✓ The bottom bar must rest on the stops when in the fully open position.
- ✓ The bottom bar must be level in both the open and closed position.

12. Procedure for installation of the Hood(s)

- a. If provided, mount intermediate hood support to a structurally stable location on wall as shown in Figure 19 using installer supplied fasteners.
- b. Attach hood to headplate hood bands with self-drilling fasteners provided and approved by ASTA Door Corporation. Use two fasteners per flat hood surface as shown in Figure 20.
- c. Overlap multiple hood segments and attach to center hood supports with self-drilling fasteners.

- d. Attach top hood flange securely to the wall with installer supplied fasteners, 2" from ends @ 24" max centers.
- ✓ Use masonry fasteners for masonry walls.
 - ✓ On non-masonry walls install hood flange to each available wall stud with 1/4" min. diameter fasteners x length appropriate to extend thru substrate.
 - ✓ The use of fire caulk may be required to eliminate gaps unsuitable to contractor or the Authority Having Jurisdiction.

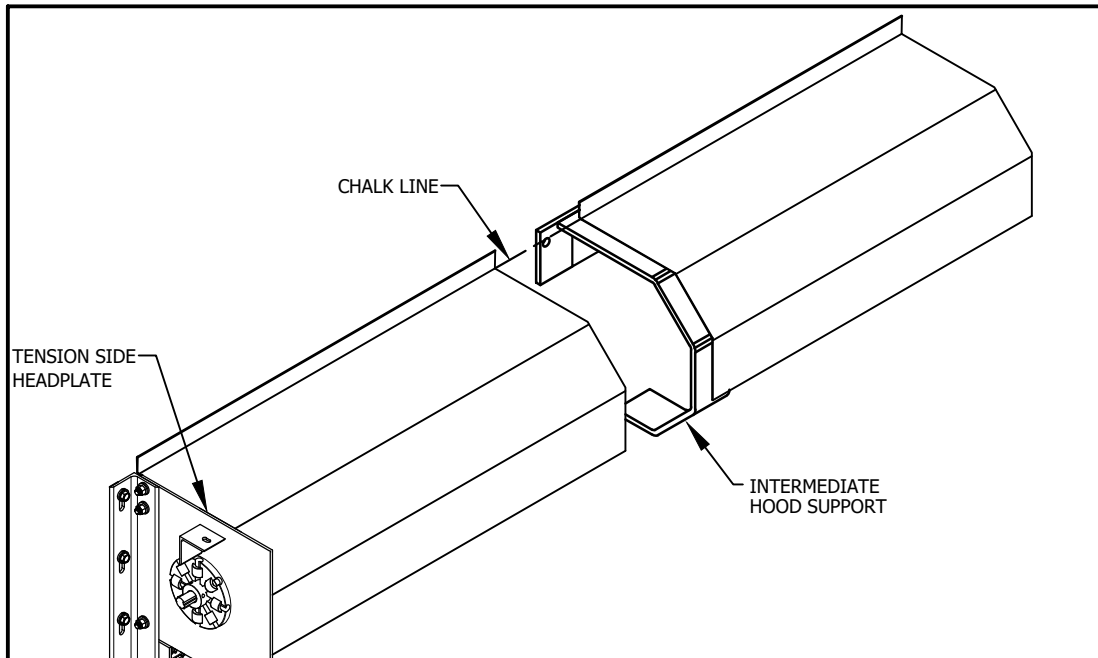

FIGURE 19

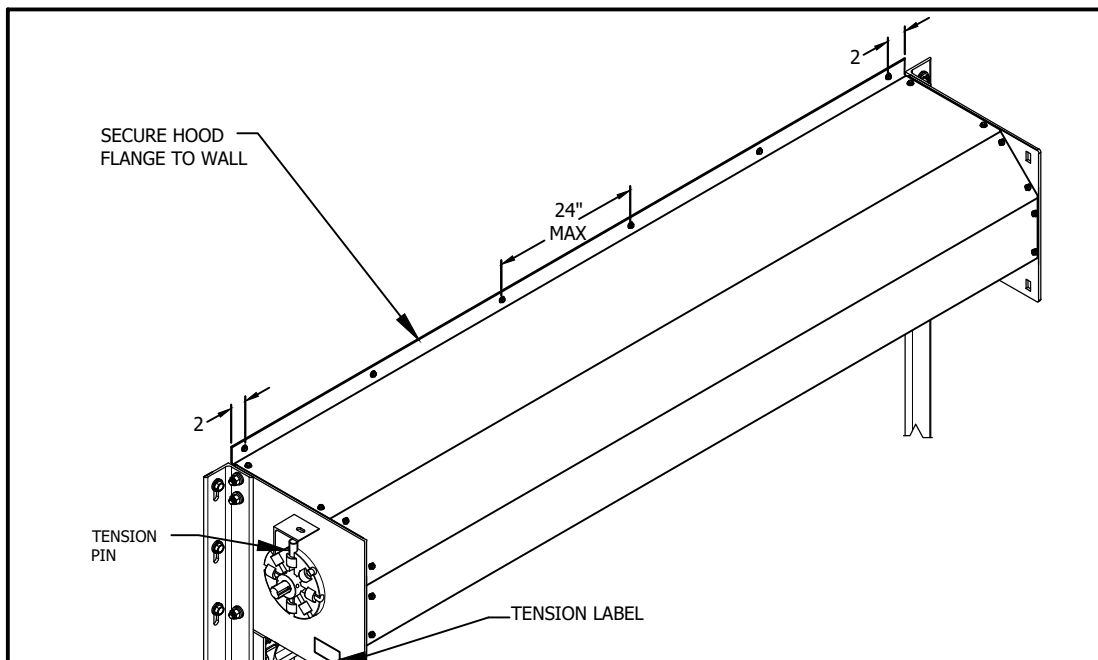

FIGURE 20

Note: You may now proceed with drop testing. See Appendix B for further instructions.

Appendix "A"

Route the cable in such a manner that the separation of any fusible link, or release by a release device, will allow the cable to completely slack and allow the fire door to close by releasing the fire door operator, as instructed in the supplemental operator instruction manual. See Figure A-1.

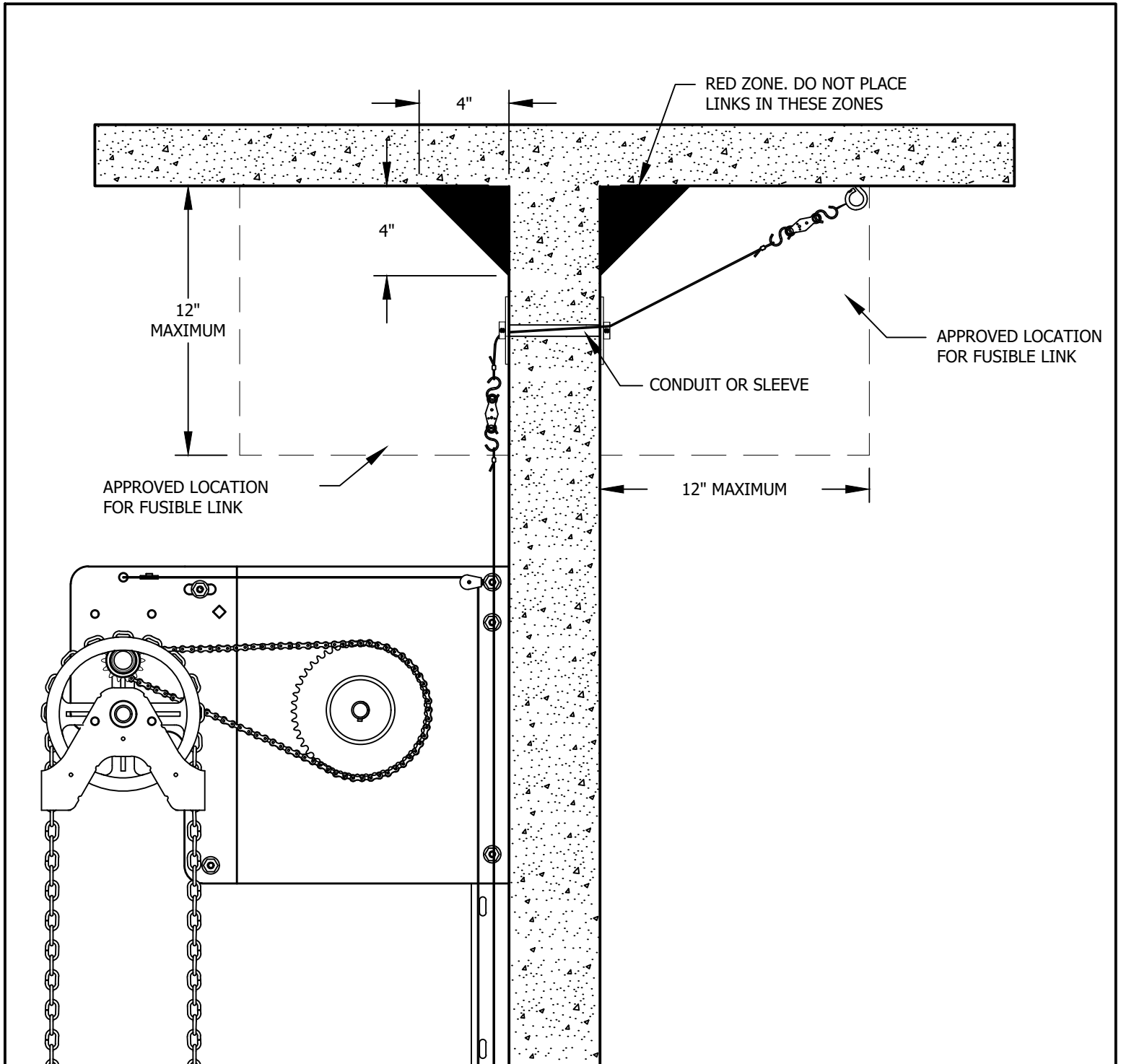

FIGURE A-1

The upper fusible link locations, per NFPA-80 are shown in Figure A-1. A third fusible link is located near the drive side headplate close to the opening height.

Three fusible links, cable, ferrules, S hooks and a test handle are provided with each ASTA door. Fusible links are attached to the cable by fashioning a loop in the cable and attaching this loop with an S hook as shown in Figure A-2.

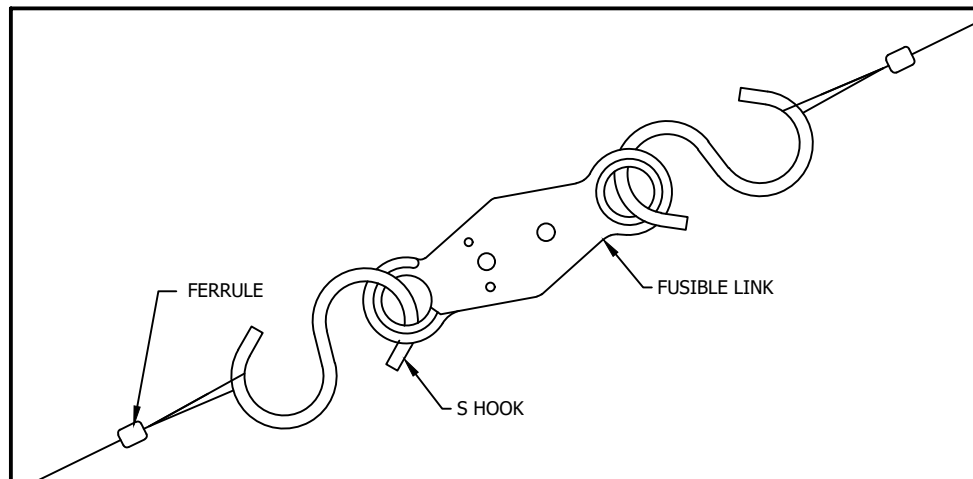

FIGURE A-2

The upper fusible link locations, per NFPA-80 are shown in Figure A-2. A third fusible link is located near the drive side headplate close to the opening height.

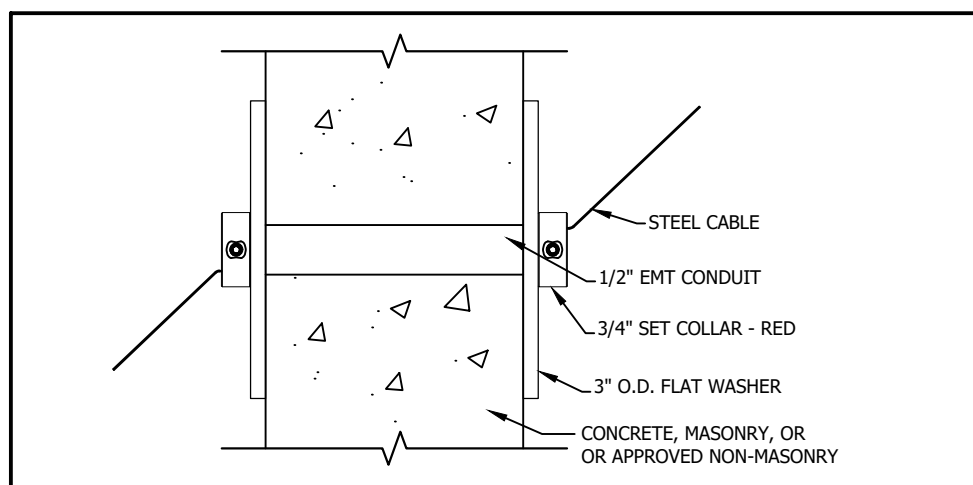

FIGURE A-3

DROP TESTING ASTA FIRE DOORS:

Creating and Adjusting the Out of Balance Condition

ASTA fire doors require that the door be placed in a permanent out-of balance condition to allow the door to reliably close from any normal operating position when activated by alarm, notification or release device.

This out of balance condition will not affect normal operation. It is a standard procedure for ASTA fire doors and is necessary to enable the door to drop test correctly and to close reliably in the event of a fire or alarm.

Please follow the following out-of-balance procedure carefully.

1. Clear the path of the doorway and barricade from passage of personnel or vehicular traffic.
2. With curtain in the fully open position, install locking pliers on each guide approximately 4" - 6" below curtain stops to arrest downward curtain travel as shown in Figure 18.
3. Disengage the test handle, or operator release mechanism at this time.
4. Begin releasing spring preload tension using winding bars and the tension wheel, in reverse order as shown in Figure 18, until barrel begins to rotate towards the closed position.
 - a. Release enough preload tension to allow the curtain to readily move downward and come to a stop on the locking pliers.
 - b. Minimum preload is zero tension plus 1/8 turns on the tension wheel.
 - c. Install tension pin to secure tension wheel.
5. Re-engage test handle or motor release mechanism, and operate door to full open position.
6. You may now drop test the door per supplemental operator instructions.
 - a. If you wish to initially drop test the door to stop on the locking pliers, you may do so at this time. If not, you may remove the locking pliers from the guide angles.
 - b. If you desire to drop test the door with the curtain position closer to the floor to more fully familiarize yourself with the procedure, you may do so at this time. ASTA fire doors may be released from any normal operational position with no harm to the fire door or operational assemblies.
7. Drop test the door from the fully open position by releasing the test handle or motor release mechanism at this time.
 - a. Door should start downward readily and close completely to the floor in a safe and controlled manner.
 - b. Curtain speed shall average not less than 6" per second and not more than 24" per second from the time of release to reaching the floor.
 - c. Repeat steps #1 through #6 on this page for further out of balance adjustments.
 - d. Complete all instructions and documentation on drop test form and apply date.

ASTA AMERICA 500 Series FIRE DOOR Motor Operator Installation

1. Verify the barrel and guide assemblies are properly installed and that all fasteners are tightened securely.
2. Procedure for installation of motor operator.
 - a. Attach the operator to bracket using the supplied hex bolts, flat washers, lock washers and hex nuts as shown in Figure C-1 & C-2.
 - b. Install motor operator and bracket assembly to the drive side headplate with two 1/2" -13 NC X 1 1/4" carriage bolts as shown in Figure C-1 & C-2.
 - c. Push the assembly toward wall as far as possible for drive chain installation, and temporarily secure the two carriage bolts as shown in Figure C-1 & C-2.
 - d. Install the drive shaft sprocket with supplied key stock.
 - e. Align the drive shaft and operator sprockets and tighten set screws.
 - f. Size & install the supplied #50 roller chain and secure with #50 master link.
 - g. Loosen the operator carriage bolts and tighten the roller chain by pulling the assembly away from the wall leaving approximately 3/4" slack in chain.
 - h. Tighten operator bracket carriage bolts and set screw to lock the bracket in place and to retain roller chain setting during future operation.

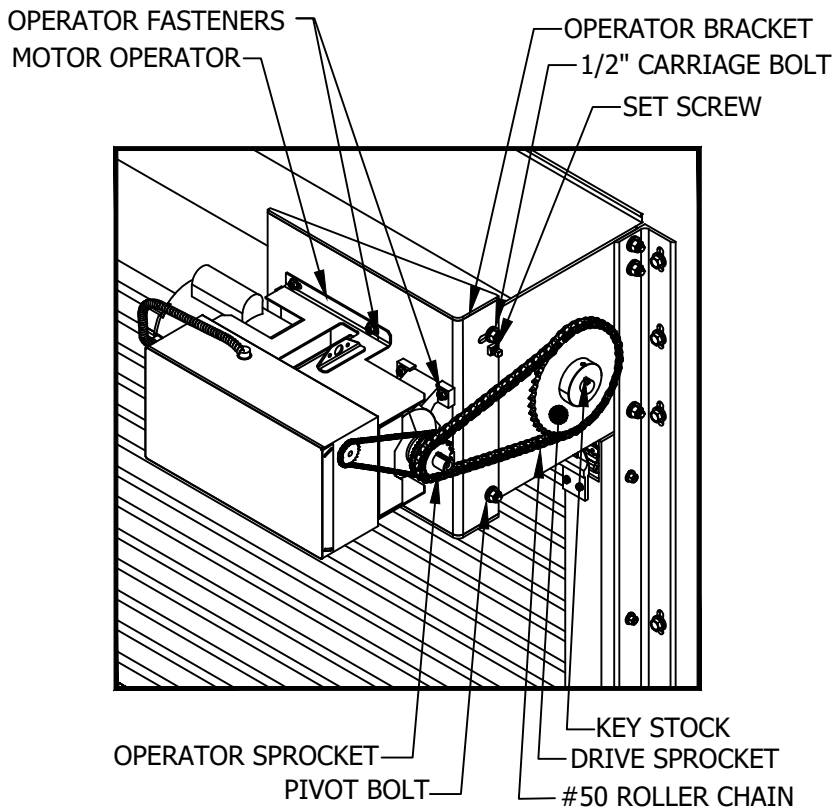

FIGURE C-1
LIFTMASTER OPERATOR

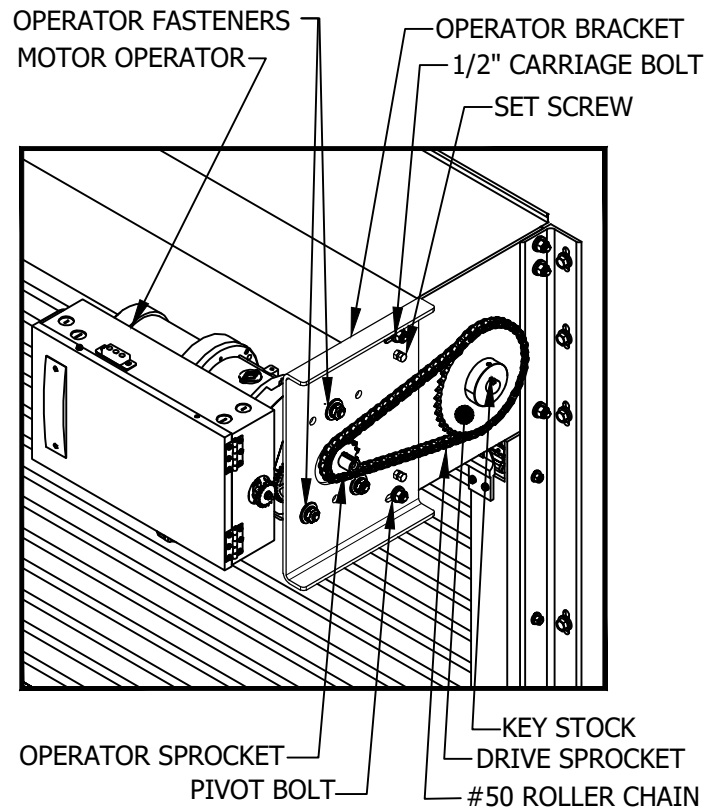

FIGURE C-2
McKEON OPERATOR

**FIRE DOOR 500 SERIES
BASE INSTALLATION MANUAL**



ASTAAMERICA

BY JANUS INTERNATIONAL

**638 Cassville White Rd NW
Cartersville, GA 30121
P.O. Box 639
Cassville, GA 30123**

**Office: 770-974-2600
Fax: 770-974-1455
www.astadoor.com**